

HD-SDI Output Full-HD Color Camera

Model KC200SB1CX

Instruction Manual

Version 2.0

Before using this product, be sure to read this instruction manual.





2nd floor, Kudan Center Building, 4-1-7 Kudankita, Chiyoda-ku, Tokyo 102-0073 Japan

TEL +81-3-6272-5967



*The contents of this document are subject to change without prior notice.







Safety Precautions

Meaning of indication

 WARNING	Indicates a hazardous situation which, if the precaution with this indication is not observed, could result in death or serious injury.
 CAUTION	Indicates a hazardous situation which, if the product is erroneously handled by ignoring the precaution with this indication, could result in bodily injury and/or property damage.

Meaning of symbol

	Indicates a “prohibited action.”
	Indicates a “matter to which you should pay attention.”

 WARNING	
	If an abnormality, such as smoke, strange odor, abnormal sound, or entry of water or foreign matter in the product, occurs, immediately stop using the product. Use of this product with an abnormality or failure may cause fire or electric shock.
	Do not disassemble or modify this product. Failure to follow this instruction may cause fire, electric shock, or failure.
	Securely fix this product. Failure to follow this instruction may cause it to fall.
	Make sure that water and foreign matter do not enter the product. Failure to follow this instruction may cause fire, electric shock, or failure.
	Use the specified power voltage. Connect and disconnect the connection cable with the power supply turned off. Failure to follow this instruction may cause fire, electric shock, or failure.
	Connect cables according to the instructions. Do not damage, forcefully bend, or pull cables. Failure to follow this instruction may cause fire, electric shock, or failure.







 CAUTION	
	Do not use this product in an environment out of its operating environmental range. Failure to follow this instruction may cause the product to fail.
	Do not drop this product or give a strong shock to it. Failure to follow this instruction may cause the product to break or fail.
	Do not install this product at a location subject to direct sunlight or heat for a long period. Failure to follow this instruction may cause the product to fail.
	Do not short-circuit the signal output. Failure to follow this instruction may cause the product to fail.
	When the lens is removed, dust may occur on the lens mount. This may cause the dust to be displayed in the images, so please clean the lens mount if necessary.
	Do not orient the camera upward. Failure to follow this instruction may cause dust to get into the sensor.

Table of Contents

1. Scope of Application	5
2. Product Overview	5
3. Configuration	5
4. Specification	6
5. Appearance Drawing and Functions of Components.....	8
6. Rear Connector.....	11
7. Operation.....	12
8. Disclaimer	45
9. Federal Communications Commission	46
10. Environmental protection notice	46
11. Others.....	46

1. Scope of Application

This instruction manual applies to the “HD-SDI output full-HD color camera” model KC200SB1CX.

2. Product Overview

This product is an HD-SDI output full-HD color camera mounted with a 1/1.8" CMOS image sensor. For the lens mount, a CS mount with flange back adjustment function is employed. This product can be used in a wide variety of fields and usages such as surveillance and broadcasting. The KC200SB1CX unit must be installed with proper grounding.

3. Configuration

○Camera Body	1
○Accessory		
• C/CS Mount Adapter	1
• Camera Tripod Adapter	1
• BNC-MicroBNC Adapter	1
• Power Supply Cable (0.5m)	1
• RS-485 Control / IR Cut Filter Switching Cable (0.5m)	1

4. Specification

Table 1 Major Specifications

Image Sensor	Single-panel CMOS RGB Bayer array rolling shutter
Number of Effective Pixels	1920(H)×1080(V) Approx. 2 million pixels
Sensor Size	1/1.8"
Minimum Object Illuminance	0.003 lx (F1.4, 30 fps, 50 IRE, +84 dB, color)
S/N	50 dB or above ($\gamma=1$, contour correction OFF)
Lens Mount	CS mount (Maximum allowable lens protrusion from mount surface: 5 mm)
Day/Night Switching	Turning ON/OFF of IR cut filter (auto/fixed/remote control)
Increased Electronic Sensitivity	OFF, x2, x3, x4, x5, x6, x7, x8, x9, x10, x12, x15, x20, x25, x30, x35, x40, x45, x50, x55, x60
Gain	AUTO : AGC MANUAL : 0dB to 84dB
Electronic Shutter	AUTO, 1/60, 1/120, 1/180, 1/240, 1/300, 1/500, 1/1000, 1/2000, 1/5000, 1/10000 seconds
Backlight Compensation	OFF, BLC, HLM
Gamma Correction	DEFAULT / 0.4 / 0.45 / 0.5 / 0.55 / 0.6 / 0.7 / 0.75 / 0.8 / 0.9 / OFF-BYPASS
DNR	OFF, 2D, 3D, 2D+3D
White Balance	ATW / ONE PUSH / MANUAL
WDR Mode	OFF / ON
Fog Removal	OFF / AUTO / ON
Other Image Qualities	EDGE ENHANCE / HUE / BRIGHTNESS
Electronic Zoom	x1.00 x6.00
Image Inversion	Right-left inversion/up-down inversion/right-left up-down inversion
Privacy Mask	8 masks SQUARE / POLYGON
Test Pattern	Color bar / gray scale / cross-hair, etc.
Serial Port	RS-485 (original protocol)
Contact Input	IR cut filter switching
Video Output	HD-SDI (1080i59 / 1080i60 / 1080p25 / 1080p29 / 1080p30 / 1080i50) Composite video NTSC, PAL down conversion
Interfaces	Power Supply • Miniature circular connector ×1 (Hirose Electric Co., Ltd. HR10A-7R-4SB) RS-485 Control / IR Cut Filter Switching • Miniature circular connector ×1 (Hirose Electric Co., Ltd. HR10A-7R-6SB) Video Output • HD-SDI (HD-BNC) ×1 • Composite video (VBS) (HD-BNC) ×1 Iris Control • 4-pin DC iris control ×1

Power Supply Input	DC 12 V \pm 10% (ripple: 50 mVp-p max.) <ul style="list-style-type: none"> • At power-on, the supply voltage must increase monotonically with the camera connected (hot plugging is not permitted). • Apply the supply voltage only when the power source is capable of delivering the current required for camera startup. • The power-off time (duration which the supply voltage is 0 V) must be at least 500 ms.
Power Consumption	4.5W
Operating Temperature/Humidity	0 to 50°C / 35 to 90%RH
Storage Temperature/Humidity	-20 to 60°C / 20 to 90% RH
External Dimensions	50 (W) \times 50 (H) \times 45 (D) (mm: protrusions not included)
Mass	Approx. 120 g (excluding accessories)
Standards	CE (EN50130-4, EN55022 class A) FCC part-15 class A RoHS2

5. Appearance Drawing and Functions of Components

(Unit: mm)

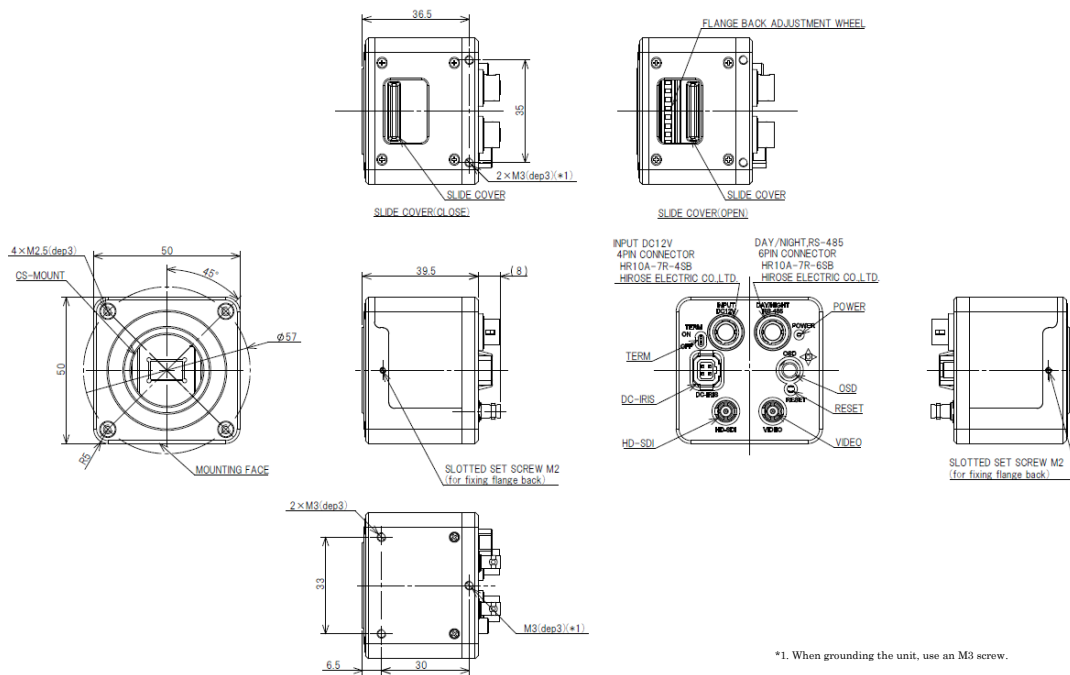

Fig. 1 Appearance Drawing

* Use a lens whose protrusion from the lens mount flange surface is 5 mm or less.

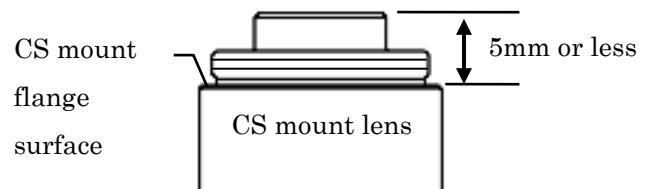

Fig. 2 Lens

Table 2 Component Functions

Name	Function
CS-MOUNT	<p>The mount for lens installation. CS mount lens can be used.</p> <p>When using a C mount lens, attach the supplied C/CS mount adapter.</p>
FLANGE BACK ADJUSTMENT WHEEL	<p>Adjusts the flange back (distance from lens mounting surface to imaging surface).</p> <p>When performing flange back adjustment, be sure to turn this wheel after loosening the two M2 setscrews located on the right and left sides of the camera.</p> <p>Turning the FLANGE BACK ADJUSTMENT WHEEL all the way until it stops may cause the image to tilt.</p>
SLOTTED SET SCREW M2	<p>When adjusting the flange back of the camera, loosen the slotted M2 setscrews at two locations and, after adjustment, tighten the setscrews.</p>
INPUT DC12V (4PIN CONNECTOR (HR10A-7R-4SB))	<p>Input 12 V DC. Pay attention to their polarities.</p> <p>(Failure to follow this instruction may cause the camera to be broken.)</p>
DAY/NIGHT,RS-485 (6PIN CONNECTOR (HR10A-7R-6SB))	<p>This is used when connecting RS-485 or performing remote day/night switching.</p>
TERM	<p>RS-485 differential signal termination is OFF by default.</p> <p>Turn it ON (100 Ω termination) as necessary, considering signal integrity.</p> <p>Use an insulated tool for this operation.</p>
OSD	<p>The joystick button for setup mode operation. Holding down this button for 2 seconds or longer will displays the OSD MENU.</p>
DC-IRIS	<p>The connector for the auto iris lens. This is compatible with DC iris only.</p>

RESET	Use to restart the camera.
HD-SDI	The image output terminal for HD-SDI.
VIDEO	The analog video output terminal for VIDEO.
M3(dep3)	These screw holes are for camera mounting or grounding. Use M3 screws with a thread engagement of 3 mm or less.
SLIDE COVER	Slide the top cover forward and backward to access the FLANGE BACK ADJUSTMENT WHEEL. After adjustment, return the cover to its original position.

Table 3 Adjustment Methods of Components

Name	Adjustment method
Flange back adjustment method	<ol style="list-style-type: none"> 1. By using a flathead screwdriver, loosen the slotted M2 setscrews at two locations in total on the right and left sides of the camera. (Do not loosen the setscrew excessively, as it may come out. Loosen it by approximately one turn.) 2. Slide the cover toward the rear of the camera. 3. Turn the flange back adjustment wheel located on the top surface of the camera to adjust the flange back. 4. Return the slide cover to its original position. 5. After adjusting the flange back, tighten the slotted M2 setscrews. (Take measures against loosening of screws by using screw lock or other) (Recommended tightening torque: 2 cNm)

6. Rear Connector

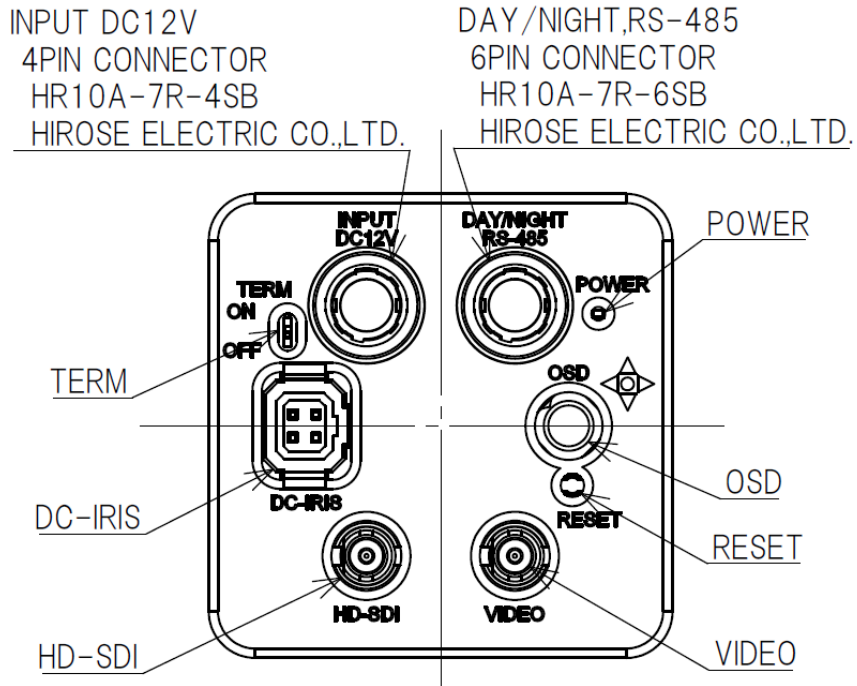

Fig. 3 Connectors on rear face

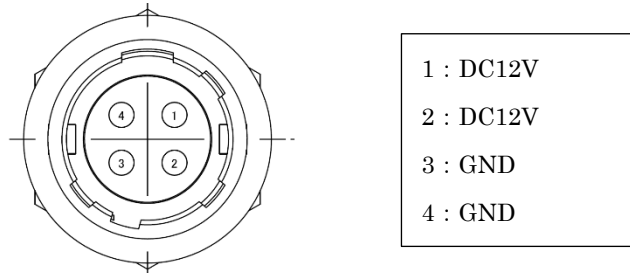

Fig. 4 Pin assignment of 4PIN CONNECTOR (Hirose Electric Co., Ltd. HR10A-7R-4SB)

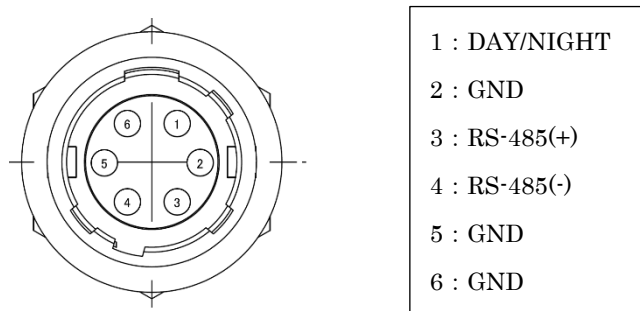

Fig. 5 Pin assignment of 6PIN CONNECTOR (Hirose Electric Co., Ltd. HR10A-7R-6SB)



Fig. 6 HD-SDI connector (HD-BNC female connector)

7. Operation

Camera setup can be performed by operating the joystick provided on the rear panel.

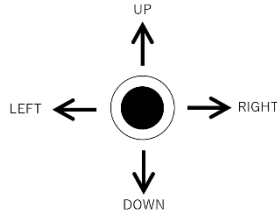

Pressing the joystick once serves as “Enter”.
Holding down the joystick for 2 seconds or longer turns on the MAIN MENU.

Holding down this joystick for 2 seconds or longer displays the MAIN MENU where you can configure various camera operation settings. Moving the joystick up or down allows you to select an item, and moving the joystick right or left allows you to change the setting value of the currently selected item. If the selected item has a sub menu (with “>” indicated at the right end), executing “Enter” allows you to enter the sub menu.

【MAIN MENU】

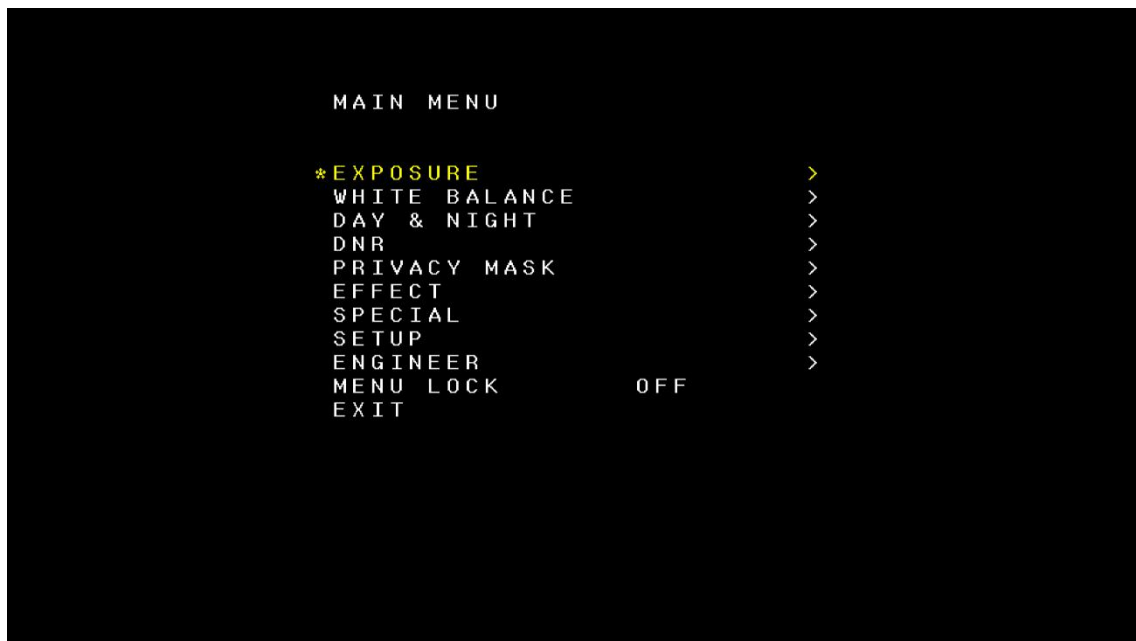

- (i) EXPOSURE : Refer to “7-1 【EXPOSURE】 MENU”.
- (ii) WHITE BALANCE : Refer to “7-2 【WHITE BALANCE】 MENU”.
- (iii) DAY & NIGHT : Refer to “7-3 【DAY & NIGHT】 MENU”.
- (iv) DNR : Refer to “7-4 【DNR】 MENU” .
- (v) PRIVACY MASK : Refer to “7-5 【PRIVACY MASK】 MENU”.
- (vi) EFFECT : Refer to “7-6 【EFFECT】 MENU”.
- (vii) SPECIAL : Refer to “7-7 【SPECIAL】 MENU”.

- (viii) SETUP : Refer to “7-8 【SETUP】 MENU”.
- (ix) ENGINEER : Refer to “7-9 【ENGINEER】 MENU”.
- (x) MENU LOCK : Setting this to ON locks the MAIN MENU to prevent the setup details from being inadvertently reconfigured. To cancel the menu lock, press the following OSD keys in this order with the MAIN MENU displayed.

[UP] -> [Left] -> [Down] -> [Right] -> [Up] -> [Down]

* When you have pressed a wrong key, press the above keys again from the beginning.

7-1 【EXPOSURE】 MENU

Configures settings concerning exposure time, gain, and iris.



(1) AE MODE

Selects an automatic light control mode.

- (i) AUTO : Enables auto exposure (AE) and auto gain (AGC).
- (ii) SHUT FIX : Fixes the exposure time to the set value, and enables AGC only.
- (iii) AGC FIX : Fixes the gain to the set value, and enables AE only.
- (iv) MANUAL : Fixes the exposure time and gain to set values.

(2) SHUTTER

Sets the exposure time.

AUTO (when AE MODE is AUTO/AGC FIX)

1/60, 1/120, 1/180, 1/240, 1/300, 1/500, 1/1000, 1/2000, 1/5000, and 1/10000 seconds

(3) AE MIN

Sets the exposure time lower limit during AE.

1/60, 1/120, 1/180, 1/240, 1/300, 1/500, 1/1000, 1/2000, 1/5000, and 1/10000 seconds

(4) GAIN

Sets the gain value.

AUTO (when AE MODE is AUTO/SHUT FIX)

0 to 36 dB (analog gain), 37 dB to 84 dB (digital gain)

(5) AGC MAX

Sets the maximum value of gain during AGC.

OFF(0dB) , LOW(20dB) , MIDDLE(32dB) , HIGH(36dB) , DMIN(52dB) ,

DMID(68dB) , DMAX(84dB)

(6) SENS UP

Sets the accumulated exposure action.

OFF, x2, x3, x4, x5, x6, x7, x8, x9, x10, x12, x15, x20, x25, x30, x35, x40, x45, x50,
x55, x60

(7) AE BRIGHT

Sets the brightness target level during automatic light control.

(8) AGC SPEED

Sets the speed level by which the brightness reaches the target brightness in automatic light control. The lower the value is, the higher the speed is, but the more likely the hunting occurs.

(9) IRIS MODE

Sets the DC iris operation mode. Select OPEN if a DC iris is not connected.

(i) AUTO : automatically adjusts the iris.

(ii) OPEN : fully opens the iris.

7-2 【WHITE BALANCE】 MENU

Configures settings concerning white balance.

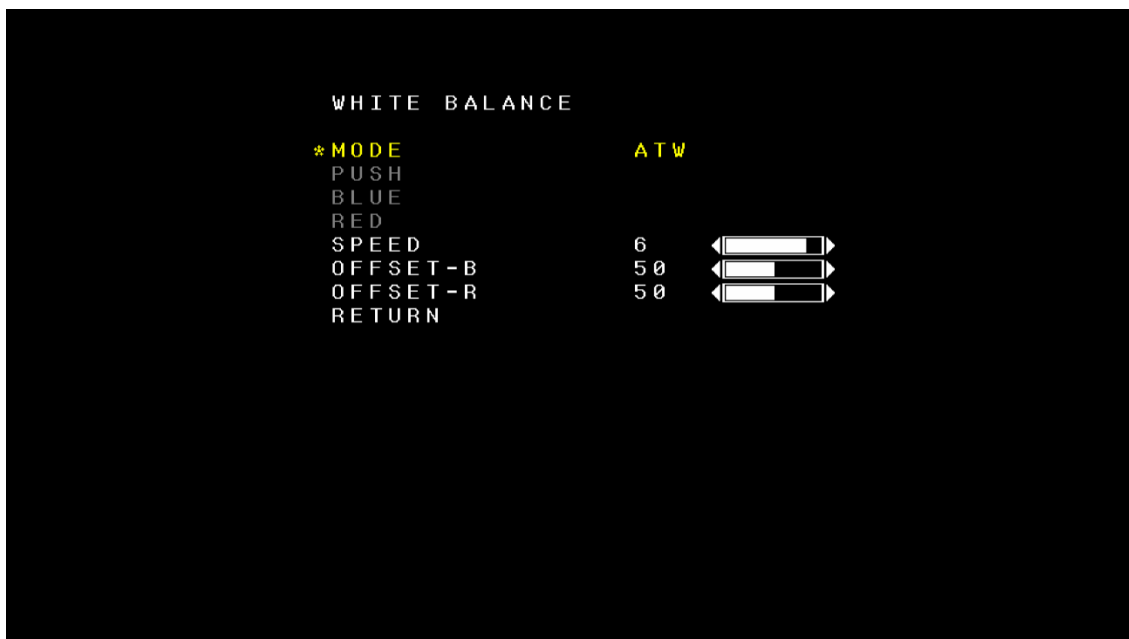

(1) MODE

Sets the white balance (WB) adjustment mode.

- (i) ATW : Automatic Adjustment (Continuously)
- (ii) ONE PUSH : Automatic Adjustment (Adjust only once and the value is retained)
- (iii) MANUAL : White balance is manually adjusted.

(2) PUSH

In the ONE PUSH mode, executing “Enter” conducts white balance adjustment.
PRESS OK (adjustment is possible)/WAIT... (Adjustment in progress)

(3) BLUE / RED

In the MANUAL mode, sets the strength of the blue/red gain.

(4) SPEED

Sets the operation speed in the ATW mode.

(5) OFFSET-B / OFFSET-R

Sets the blue/red offset in the ATW and ONE PUSH modes.

7-3 【DAY & NIGHT】 MENU

Configures settings concerning the IR cut filter.

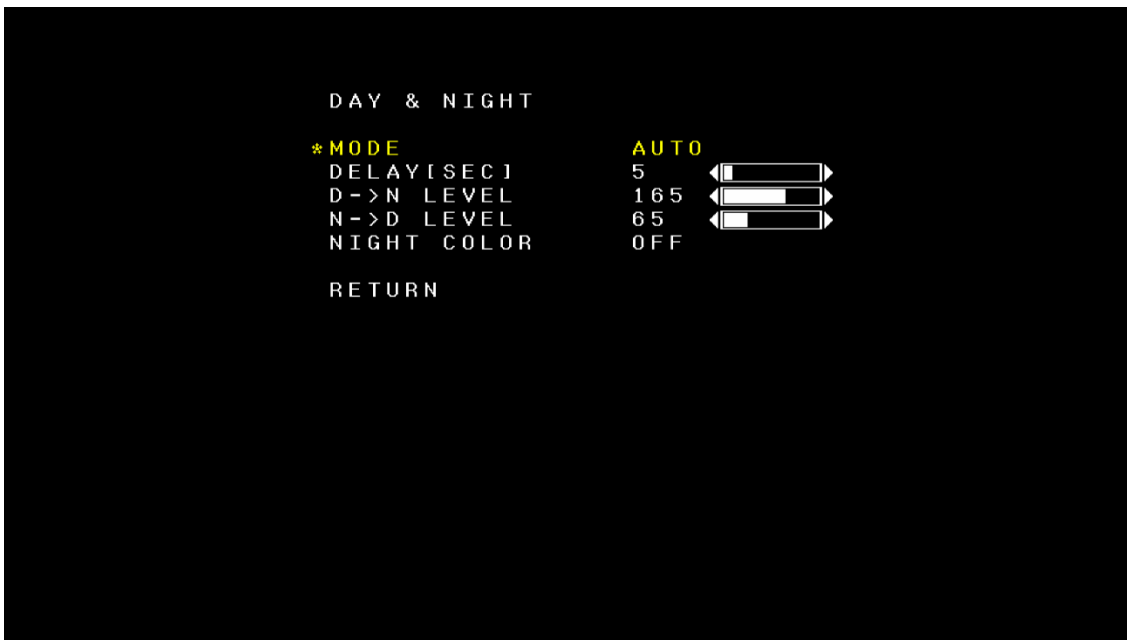

(1) MODE

Sets the IR cut filter operation mode.

- (i) AUTO : Automatically switches the IR cut filter.
- (ii) DAY(COLOR) : Sets constant color images (IR cut filter ON).
- (iii) NIGHT(B/W) : Sets constant monochrome images (IR cut filter OFF).
- (iv) EXT : Switches the DAY/NIGHT mode from the outside.

(2) DELAY

Sets the delay of DAY <=> NIGHT switching in AUTO mode.

(3) D->N LEVEL

Sets the DAY => NIGHT switching level in AUTO mode.

* It is not possible to set a value smaller than the N->D LEVEL.

(4) N->D LEVEL

Sets the NIGHT => DAY switching level in AUTO mode.

* It is not possible to set a value greater than the D->N LEVEL.

(5) NIGHT COLOR

Turning this ON obtains color images even in NIGHT mode. However, the color balance could be disrupted.

7-4 【DNR】 MENU

Configures settings concerning digital noise reduction (DNR).

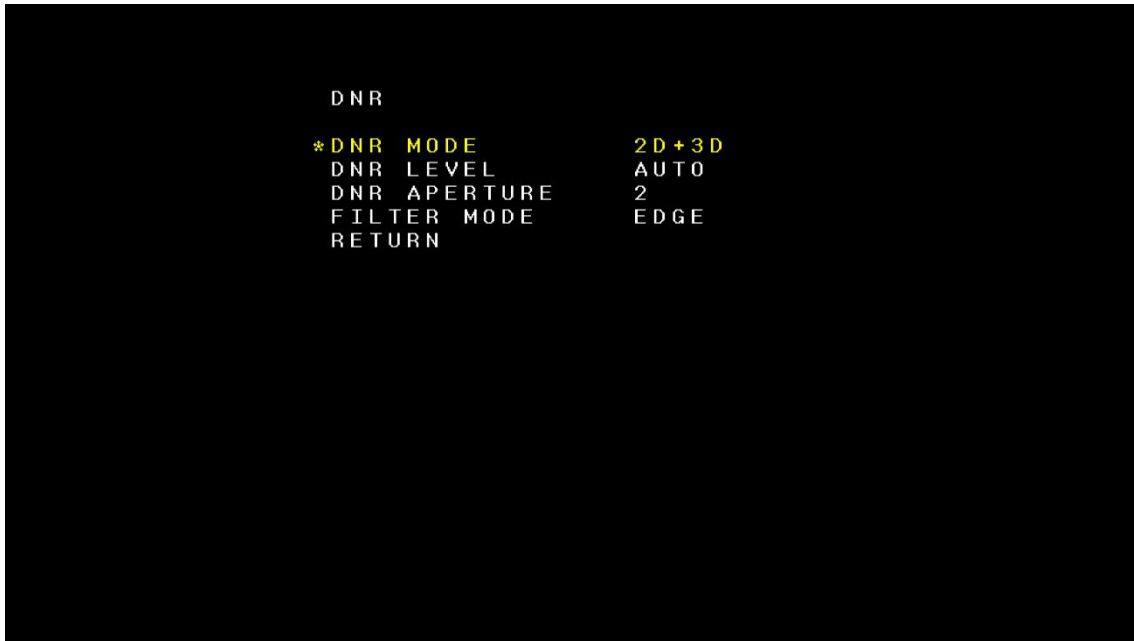

(1) DNR MODE

Sets the DNR operation mode.

- (i) 2D+3D : Uses both 2D and 3D.
- (ii) 3D : Uses 3D noise reduction only.
- (iii) 2D : Uses 2D noise reduction only.
- (iv) OFF : Disables noise reduction.

(2) DNR LEVEL

Sets the DNR level.

AUTO / LOW / MIDDLE / HIGH

(3) DNR APERTURE

Sets the 3D DNR strength. The stronger the 3D DNR is, the greater the motion artifact.

(4) FILTER MODE

Sets the 2D DNR mode.

- (i) EDGE : Reduces the noise while keeping the contour of the image.
- (ii) STRONG : Performs noise reduction more strongly than EDGE mode, but contour blurring increases.

7-5 【PRIVACY MASK】 MENU

Configures settings concerning the privacy mask.



(1) MODE

Set privacy mask. (ON/OFF)

(2) TYPE

Sets the shape of all masks. (SQUARE / POLYGON)

(3) MASK NO.

Select the mask whose setting is to be changed.

MASK 1 (upper left) to MASK 8 (lower right) * Default setting

(4) DISPLAY

Switches the screen display of the selected mask.

(5) COLOR

Sets the color of the selected mask.

BLACK / WHITE / GREEN / BLUE / RED / CYAN / MAGENTA / YELLOW /
GRAY-1 / GRAY-2 / GRAY-3 / GRAY-4 / GRAY-5 / GRAY-6 / MOSAIC

(6) POLY SELECT

Sets the end point whose position can be changed when POLYGON is selected.

L-TOP (upper left)/ R-TOP (upper right)/ L-BOTTOM (lower left)/ R-BOTTOM
(lower right)

(7) POSITION-X / POSITION-Y

Sets the upper left endpoint for SQUARE or the X-axis direction and Y-axis direction of the selected endpoint for POLYGON.

(8) SIZE-X / SIZE-Y

Sets the lengths in the X-axis direction and Y-axis direction of the SQUARE.

(9) DEFAULT

Returns the setting values of PRIVACY MASK MENU to factory default values.

7-6 【EFFECT】 MENU

Configures settings concerning image correction.



(1) LENS SHADING

Turning ON this setting performs correcting the peripheral light quantity increases.

(2) GAMMA CORRECT

Refer to “7-6-1 GAMMA CORRECTION OPTION.”

(3) CONTRAST

Adjusts image contrast.

(4) BRIGHTNESS

Adjusts image brightness.

(5) SATURATION

Adjusts image saturation.

(6) HUE

Adjusts image hue.

(7) EDGE ENHANCE

Adjusts the degree of contour emphasis.

(8) DEFAULT

Returns the EFFECT menu settings to their factory default values.

7-6-1 GAMMA CORRECTION OPTION

Configures settings concerning gamma correction.

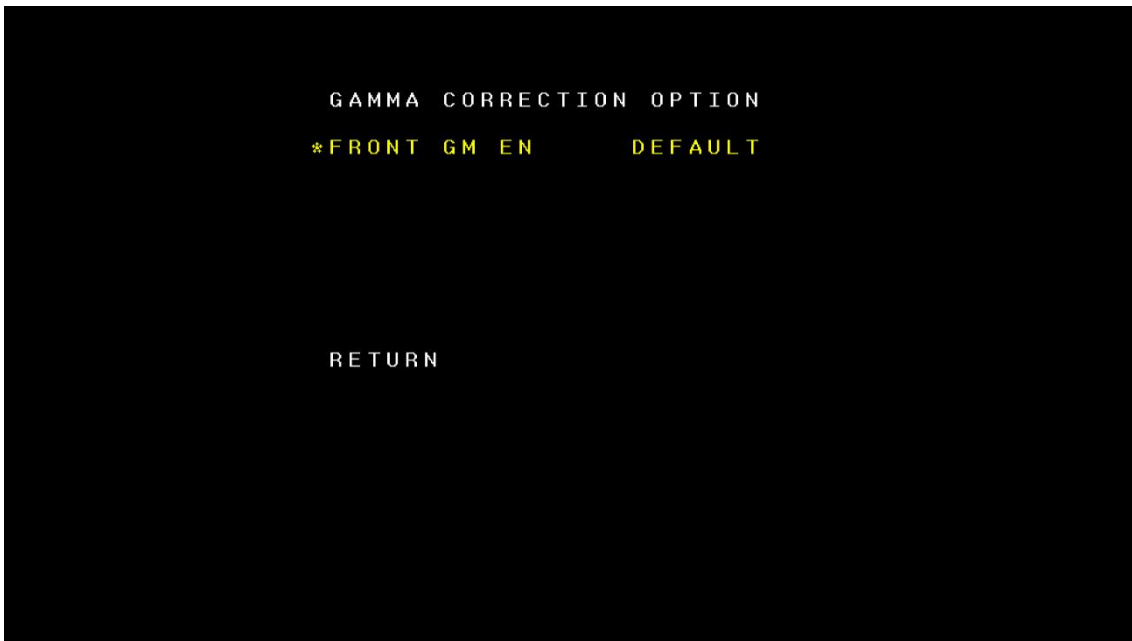

(1) FRONT GM EN

Sets the gamma correction level.

OFF-BYPASS(OFF) / 0.9 / 0.8 / 0.7 / 0.6 / 0.55 / 0.5 / 0.45 / 0.4 /

DEFAULT (0.45)

7-7 【SPECIAL】 MENU

Configures settings concerning image processing.

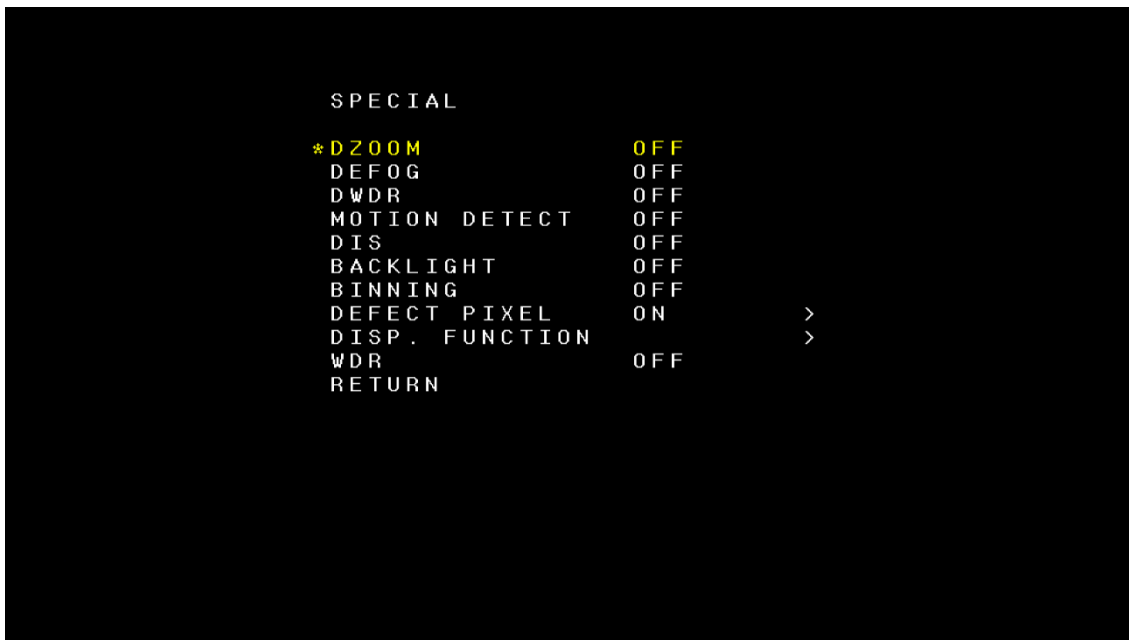

(1) DZOOM

Set the digital zoom function. (ON/OFF)

Setting this to ON allows you to configure detailed settings in the sub menu.

(Refer to 7-7-1.)

* It is not possible to enable this function and the DIS function at the same time.

(2) DEFOG

Configures the mode setting of the fog removal function.

- (i) OFF : Disables the fog removal function.
- (ii) ON : Enables the fog removal function based on the parameters set in the sub menu.
- (iii) AUTO : Automatically adjusts the fog removal function based on the parameters set in the sub menu.

Setting this to ON or AUTO allows you to configure detailed settings in the sub menu.

(Refer to 7-7-2.)

* It is not possible to enable this function and the backlight compensation function at the same time.

(3) DWDR

Configures the digital WDR mode setting. Enabling this setting emphasizes the dark part.

- (i) OFF : Disables the DWDR function.
- (ii) ON : Enables the DWDR function based on the parameters set in the sub menu.
- (iii) AUTO : Automatically adjusts the DWDR function based on the parameters set in the sub menu.

Setting this to ON or AUTO allows you to configure detailed settings in the sub menu. (Refer to 7-7-3.)

(4) MOTION DETECT

Set the motion detection function. (ON/OFF)

When this setting is enabled, areas with a white frame are displayed (up to four areas), and portions inside the areas where any motion is made are highlighted in red. If motion is detected, an alarm signal is output. (See separate sheet 'KC200SB1CX_PELCO-D_Command').

Setting this to ON allows you to configure detailed settings in the sub menu. (Refer to 7-7-4.)

(5) DIS

Set the electronic camera-shake compensation function. (ON/OFF)

When this setting is enabled, the angle of view becomes smaller. At the time of switching, the image output temporary stops.

* It is not possible to enable this function and the DZOOM and WDR functions at the same time.

(6) BACKLIGHT

Configures the backlight compensation mode setting.

- (i) OFF : Disables the backlight compensation function.
- (ii) BLC : Enables the backlight compensation function. Light control is automatically conducted in accordance with the overexposure in the area.
- (iii) HLM : Enables the highlight mask function. This masks any overexposure areas within the area in black, and light control of the area excluding the masked portions is automatically conducted.

Setting this to BLC or HLM allows you to configure detailed settings in the sub menu. (Refer to 7-7-5.)

* It is not possible to enable this function and the DEFOG function at the same time.

(7) BINNING

Set the binning function. (ON/OFF)

* It is not possible to enable this function and the WDR function at the same time.

(8) DEFECT PIXEL

Set the defective pixel compensation function. (ON/OFF)

Setting this to ON allows you to configure detailed settings in the sub menu.

(Refer to 7-7-6.)

(9) DISP. FUNCTION

Configures the setting of the display function in the sub menu. (Refer to 7-7-7.)

(10)WDR

Set the WDR function. (ON/OFF)

This is effective against overexposure and underexposure.

Setting this to ON allows you to configure detailed settings in the sub menu.

(Refer to 7-7-8.)

* It is not possible to enable this setting and the DIS and BINNING functions at the same time.

7-7-1 D-ZOOM

Configures the detailed settings of the digital zoom function.



(1) ZOOM CONTROL



RATIO : By moving the joystick right or left, it is possible to change the magnitude. (x1.00 to x6.00)

Executing "Enter" moves to POSITION.

POSITION : By moving the joystick up, down, right, and left, it is possible to change the displayed area. Executing "Enter" moves to RETURN.

(2) DEFAULT

Returns the settings of the D-ZOOM menu to their factory default values.

7-7-2 DEFOG

Configures the detailed settings of the fog removal function.

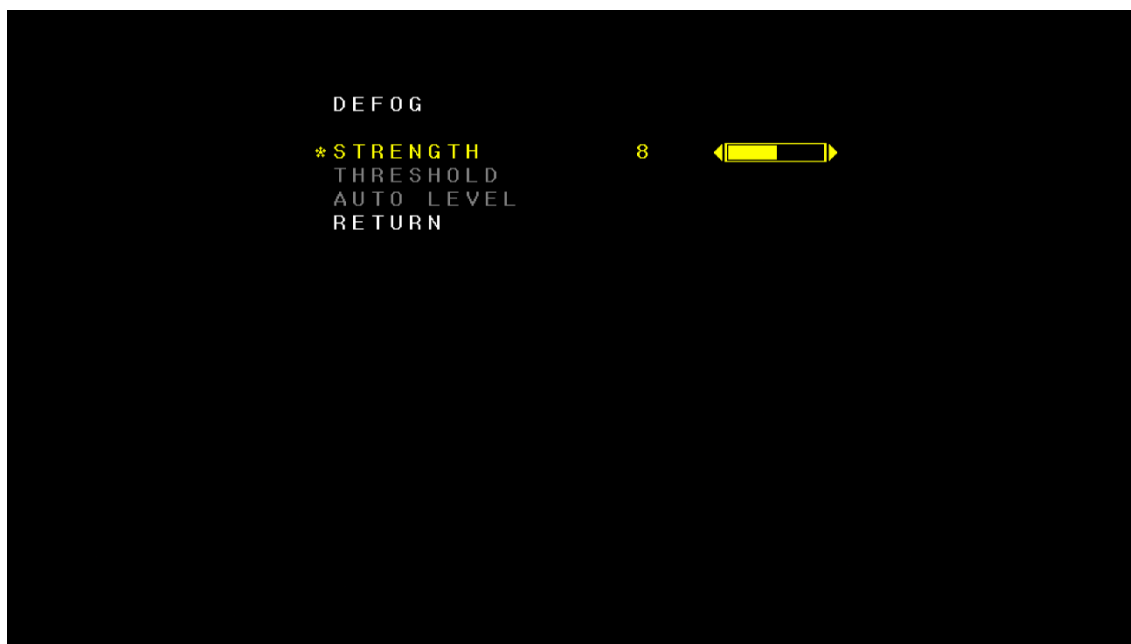

(1) STRENGTH

Sets the level of the fog removal in ON mode.

(2) THRESHOLD

Sets the threshold value for application of the fog removal function in AUTO mode.

(3) AUTO LEVEL

Sets the level of the fog removal in AUTO mode.

LOW / MID / HIGH

7-7-3 DWDR

Configures the detailed settings of the digital WDR function.

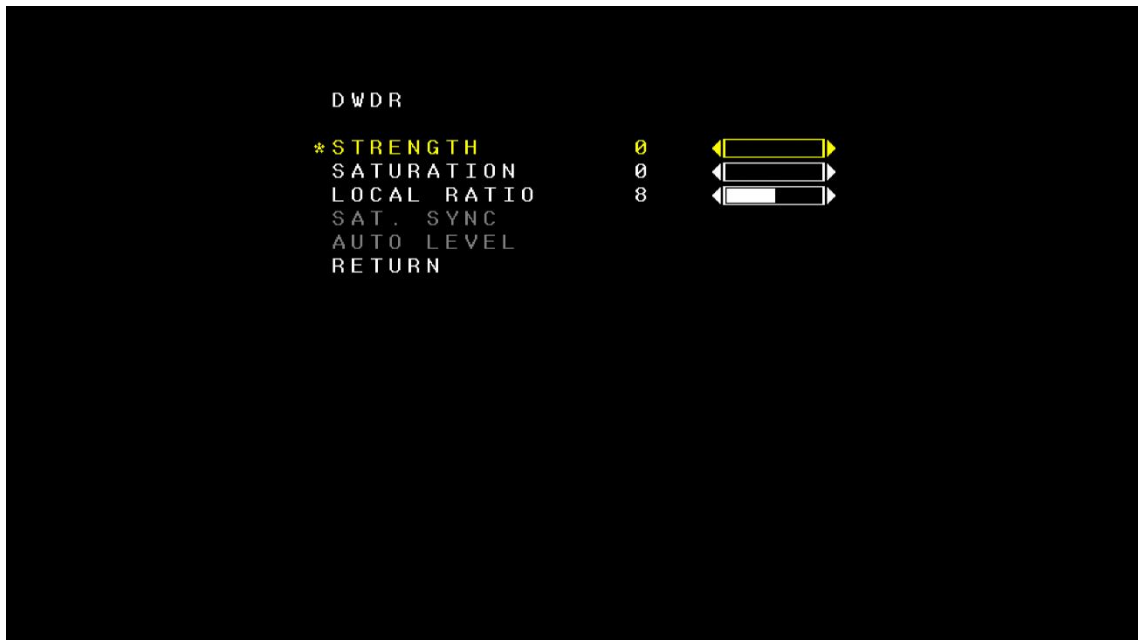

(1) STRENGTH

Sets the level of emphasis of dark part in ON mode.

(2) SATURATION

Sets the saturation in ON mode.

(3) LOCAL RATIO

Sets the contrast ratio in ON mode.

(4) SAT. SYNC

When this is set to ON in AUTO mode, the contrast is maintained while the dark part is emphasized.

(5) AUTO LEVEL

Sets the level of emphasis of dark part in AUTO mode.

LOW / MID / HIGH

7-7-4 MOTION DETECT

Configures the detailed settings of the motion detection function.

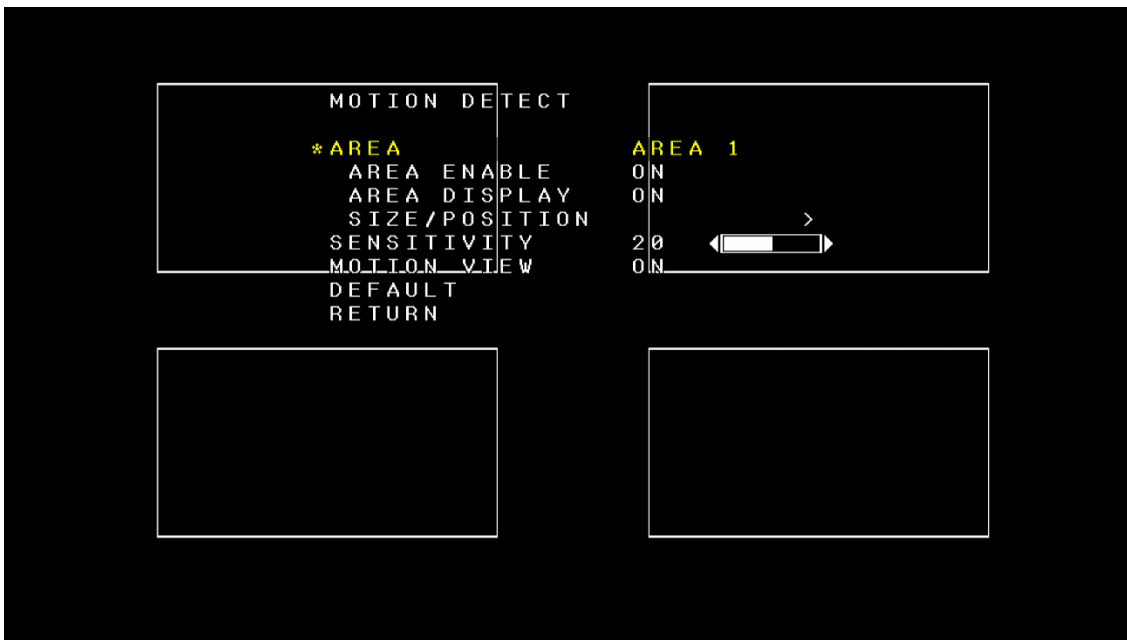

(1) AREA

Selects the area where setting change is to be made.

AREA 1 (upper left)/AREA 2 (upper right)/ AREA 2 (lower left)/ AREA 2 (lower right)

* The settings in () are default settings.

(2) AREA ENABLE

Set the area-based motion detection function. (ON/OFF)

(3) AREA DISPLAY

Switches the white frame display in the selected area.

(Even when set to OFF, the red highlight is displayed when motion is detected.)

(4) SIZE/POSITION

Changes the size and position of the selected area.



POSITION: Sets the position of the area. Executing “Enter” moves to the next item.

SIZE: Sets the size of the area.

(5) SENSITIVITY

Sets the threshold for recognition as motion. The higher the value, the lower the sensitivity; the lower the value, the higher the sensitivity.

(6) MOTION VIEW

Sets the display of the red highlight when motion is detected. (ON/OFF)

(7) DEFAULT

Returns the settings of the MOTION DETECT menu to their factory default values.

7-7-5 BACKLIGHT

Configures the detailed settings of the backlight compensation.

7-7-5-1 BLC

Configures the detailed settings of the BLC mode.

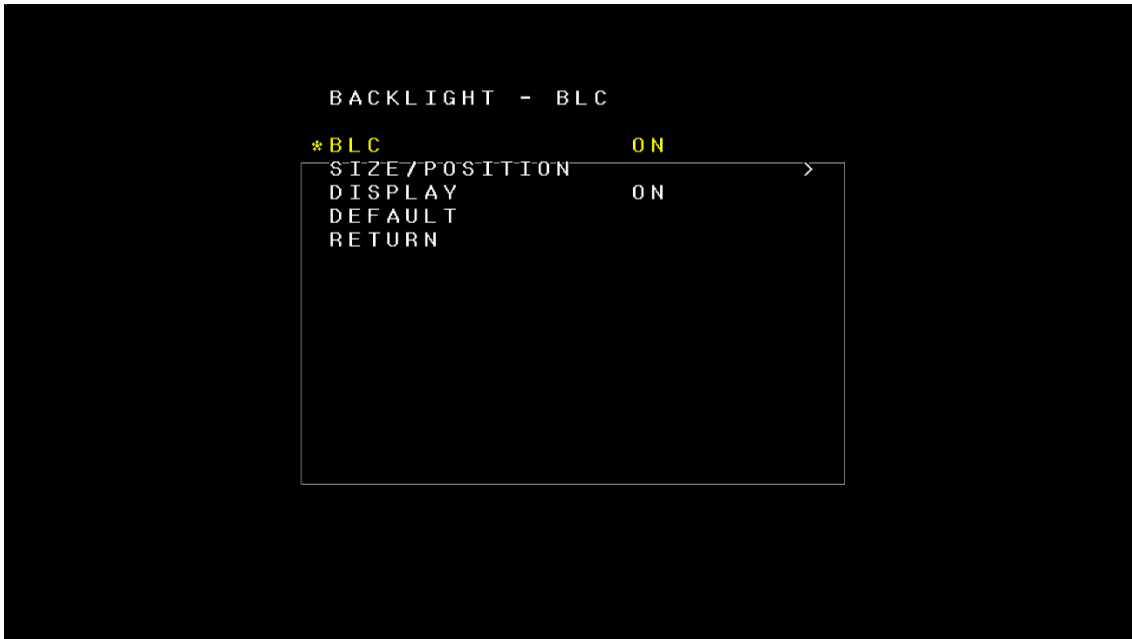

(1) BLC

Set the BLC mode. (ON/OFF)

(2) SIZE/POSITION

Changes the size and position of the BLC area.

(3) DISPLAY

Switches the white frame display in the area.

(4) DEFAULT

Returns the BLC menu settings to their factory default values.

7-7-5-2 HLM

Configures the detailed settings of the HLM mode.

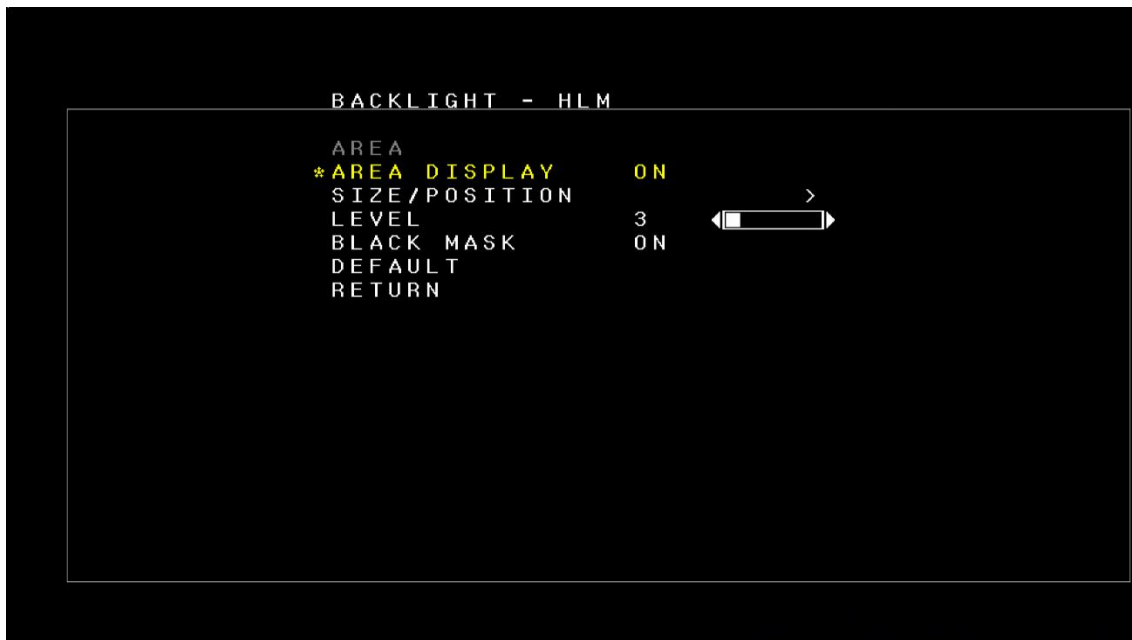

(1) AREA DISPLAY

Switches the white frame display in the area.

(2) SIZE/POSITION

Changes the size and position of the HLM area.

(3) LEVEL

Sets the level of the overexposure area to which black mask is applied.

(4) BLACK MASK

Switches the black mask display.

(5) DEFAULT

Returns the HLM menu settings to their factory default values.

7-7-6 DYNAMIC DEFECT PIXEL

Configure detailed settings of the dynamic pixel loss compensation.



(1) DDPC AUTO PARA

Configures parameters at the time of dynamic pixel loss compensation.

The displayed parameter will transit to other parameters depending on the current gain setting.

(When analog gain is used: PWR-0 to PWR-4, when digital gain is used: PWR-5 to PWR-7)

(2) DDPC THHD1

Sets the flatness threshold with respect to the surrounding area that is used in the detection of missing pixels. The larger the value, the less likely it is to be judged as a missing pixel.

- Default setting values
PWR-0 : 100, PWR-1 to PWR-7 : 15

(3) DDPC THHD2

Sets the threshold of the luminance difference from surrounding pixels to be used in the detection of missing pixels. The larger the value, the less likely it is to be judged as a missing pixel.

- Default setting values
PWR-0 : 170, PWR-1 : 35, PWR-2 : 25, PWR-3 to PWR7 : 18

(4) DDPC SEL MODE

Selects a missing pixel detection mode.

- 0 : For a flat area, **the minimum value** is used as the missing pixel judgment criterion.
- 1 : For a flat area, **the median value** is used as the missing pixel judgment criterion.
- 2 : For a flat area, **the maximum value** is used as the missing pixel judgment criterion. This is mainly used when the luminance is low.
- 3 : **The median value** is used as the missing pixel judgment criterion, with the value of DDPC THHD1 ignored.

• Default setting values

PWR-0 : 0, PWR-1 to PWR-7 : 2

(5) DPC DEBUG DISP

Indicates at the upper left of the screen to which parameter (PWR-X) of DDPC AUTO PARA is applied.

* When this is set to ON, turn OFF other indications at the upper left of the screen.

7-7-7 DISPLAY FUNCTION

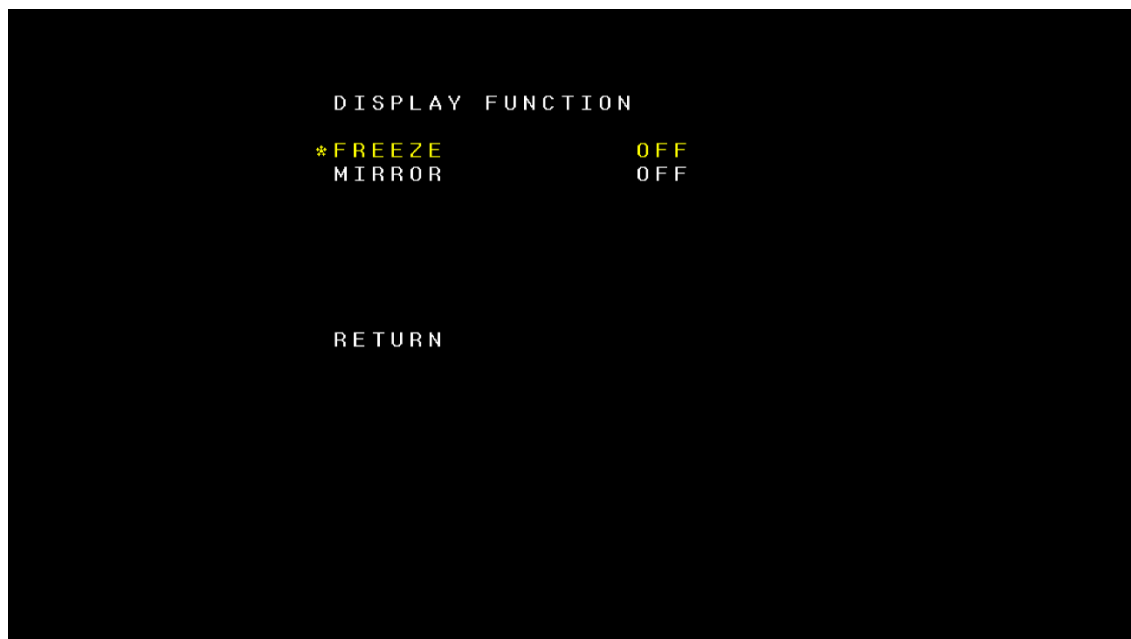

(1) FREEZE

Setting this to ON temporarily stops image output.

(2) MIRROR

Configures image inversion setting.

- (i) OFF : Normal mode
- (ii) MIRROR : Inverts the image in the horizontal direction.
- (iii) V-FLIP : Inverts the image in the vertical direction.
- (iv) BOTH(H/V) : Inverts the image in both the horizontal and vertical directions.

7-7-8 WDR

Configure the advanced WDR settings. WDR is achieved by combining images captured at long and short exposure times.

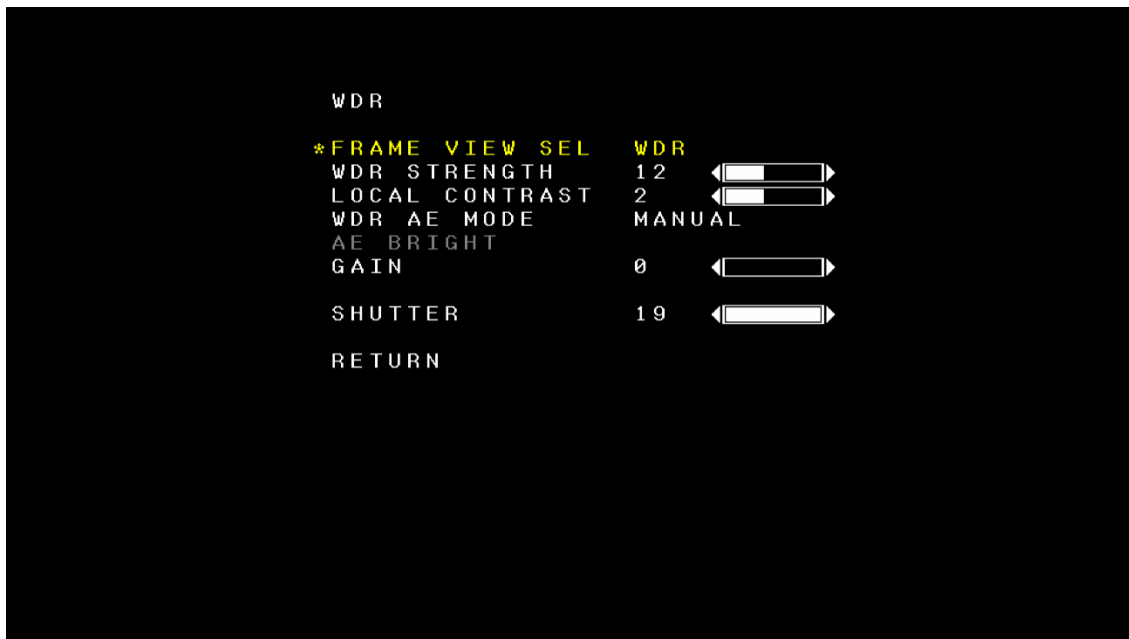

(1) FRAME VIEW SEL

Configure the image to be displayed in WDR mode.

- ① WDR : Displays the WDR composite image.
- ② LONG : Displays the image captured with a long exposure time.
- ③ SHORT : Displays the image captured with a short exposure time.

(2) WDR STRENGTH

Adjust the strength of the tone mapping. Higher values result in a brighter image.

(3) LOCAL CONTRAST

Adjust contrast of tone mapping. Higher values increase the contrast.

(4) WDR AE MODE

Configure the auto exposure mode when WDR is enabled.

- ① AUTO : Automatically adjusts the exposure time and gain.
- ② MANUAL : Manually adjusts the exposure time and gain.

(5) AE BRIGHT

Set the target brightness for automatic exposure when WDR AE MODE is set to AUTO.

(6) GAIN

Sets the gain when WDR AE MODE is set to MANUAL.

(7) SHUTTER

Sets the exposure time when WDR AE MODE is set to MANUAL.

7-8 【SETUP】 MENU

Configures camera settings.

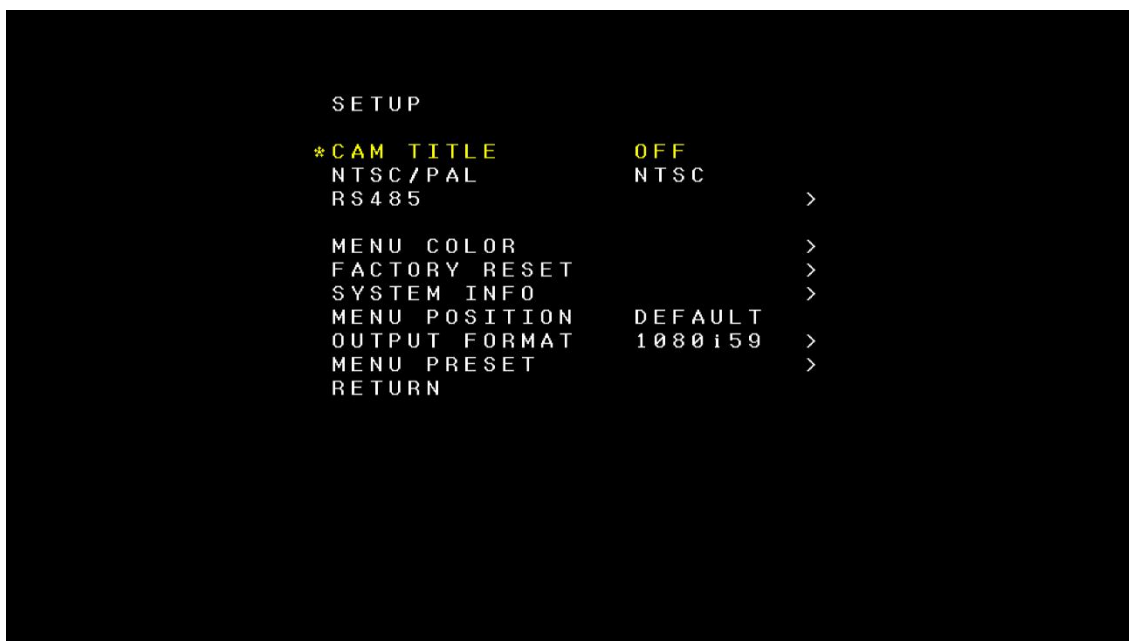

(1) CAM TITLE

Set the camera title display. (ON/OFF)

Setting this to ON allows you to configure detailed settings in the sub menu.

(Refer to 7-8-1.)

(2) NTSC/PAL

Switches the analog video standard (NTSC/PAL).

(3) RS485

Configures settings related to RS-485 communication in the sub menu. (Refer to 7-8-2.)

(4) MENU COLOR

Configures the menu color settings in the sub menu. (Refer to 7-8-3.)

(5) FACTORY RESET

Resets the camera to the factory default state and then restarts the camera.

The registered preset settings are also reset.

(6) SYSTEM INFO

Displays the system information.

(7) MENU POSITION

Sets the menu display position.

DEFAULT (center) / TOP-LEFT (upper left) / TOP-RIGHT (upper right) / BOT-
RIGHT (lower right) / BOT-LEFT (lower left)

(8) OUTPUT FORMAT

Sets the SDI output format. Selecting a format and then selecting “YES” in the submenu switches the setting. When the setting is switched, image output temporarily stops.

1080i60 / 1080i59 / 1080i50 / 1080p30 / 1080p29 / 1080p25

(9) MENU PRESET

Configures settings concerning menu presets in the sub menu. (Refer to 7-8-4.)

7-8-1 CAM TITLE

Configures detailed camera title settings.



(1) TITLE

Sets the camera title. (Up to 10 alphanumeric and symbol characters)

Moving the joystick right and left changes the selected character, and executing “Enter” moves to the next character.

List of usable characters

- Upper case alphabetic characters: A - Z
- Lower case alphabetic characters: a - z
- Symbols: ! ” # \$ % & ` () * + ’ - . /
- Numbers: 0 – 9
- Space

* Menu navigation is disabled while editing this setting. Press “Enter” after entering 10 characters to confirm the setting. If fewer than 10 characters are entered, pad the remaining spaces with space.

(2) TEXT COLOR

Changes the camera title display color.

BLACK / BLUE / GRAY / YELLOW / WHITE /BLACK OP / WHITE OP /
NO COLOR

7-8-2 RS485

Configures detailed settings of RS-485 communication.



(1) CAM ID

Sets the camera ID.

PELCO-D Protocol : 1 ~ 255

KOWA Protocol : 49 ~ 255

(2) ID DISPLAY

Sets the camera ID indication at the upper left of the screen. (ON/OFF)

* When setting this to ON, turn OFF other indications at the upper left of the screen.

(3) BAUD RATE

Sets the RS-485 communication baud rate.

2400 / 4800 / 9600 (default) / 19200 / 38400

(4) COMMAND

Set the command protocol to be used.

KOWA / PELCO-D

7-8-3 MENU COLOR

Configures menu color settings.

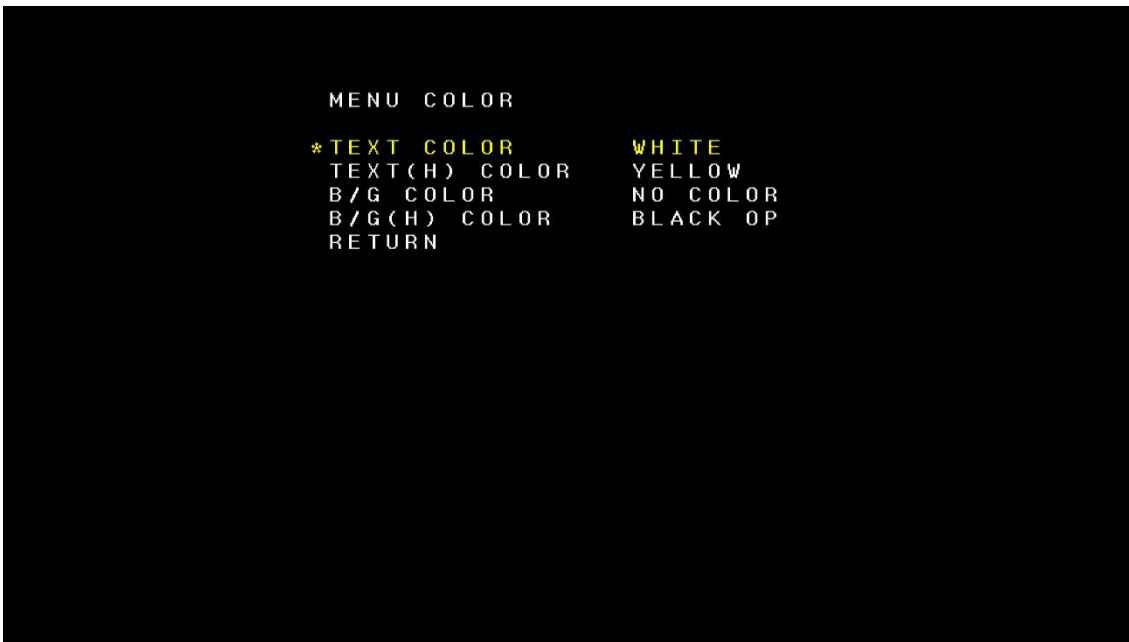

(1) TEXT COLOR

Sets the menu character color.

BLACK / BLUE / GRAY / YELLOW / WHITE /BLACK OP / WHITE OP /
NO COLOR

(2) TEXT(H) COLOR

Sets the character color in the selected state.

BLACK / BLUE / GRAY / YELLOW / WHITE /BLACK OP / WHITE OP /
NO COLOR

(3) B/G COLOR

Sets the menu background color.

BLACK / BLUE / GRAY / YELLOW / WHITE /BLACK OP / WHITE OP /
NO COLOR

(4) B/G(H) COLOR

Sets the background color in the selected state.

BLACK / BLUE / GRAY / YELLOW / WHITE /BLACK OP / WHITE OP /
NO COLOR

7-8-4 MENU PRESET

Configures menu preset settings. Menu items that can be registered as preset items are as follows.

- EXPOSURE menu and sub menu
- WHITE BALANCE menu and sub menu
- DAY & NIGHT menu and sub menu
- DNR menu and sub menu
- PRIVACY menu and sub menu
- EFFECT menu and sub menu
- SPECIAL menu and sub menu

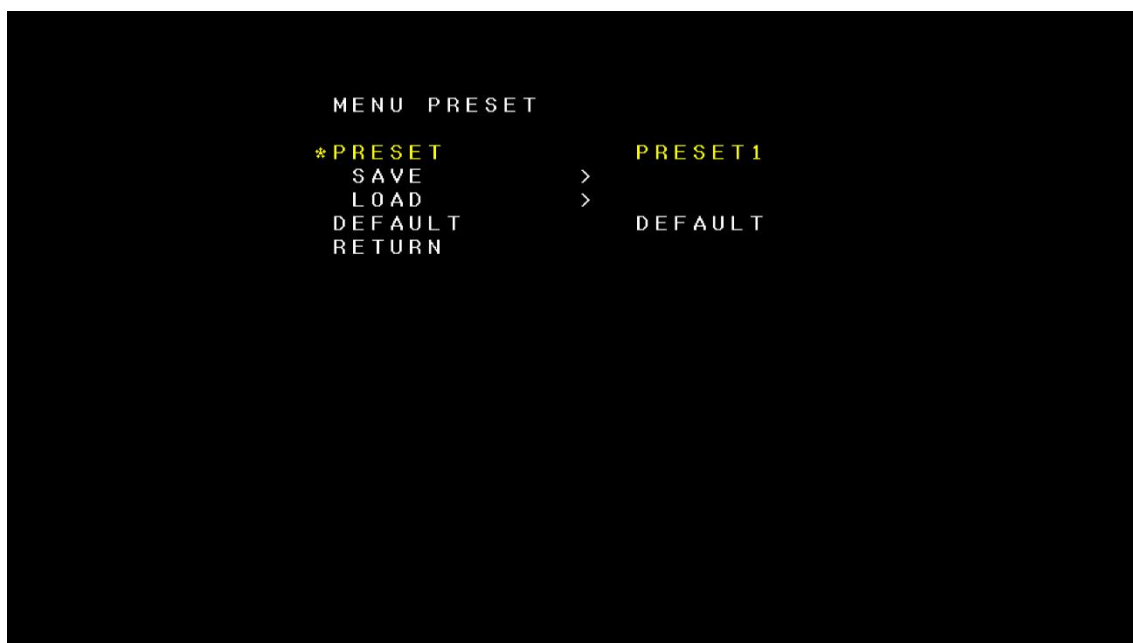

(1) PRESET

Selects the preset number to be operated.

DEFAULT / PRESET1 / PRESET2 / PRESET3

(2) SAVE

Saves the current menu settings to the selected preset number.

(It is not possible to save settings to DEFAULT.)

(3) LOAD

Applies the selected menu preset. In DEFAULT, the factory default parameters are applied.

(4) DEFAULT

Selects the preset to be applied at the time of turning on the power supply.

7-9 【ENGINEER】 MENU

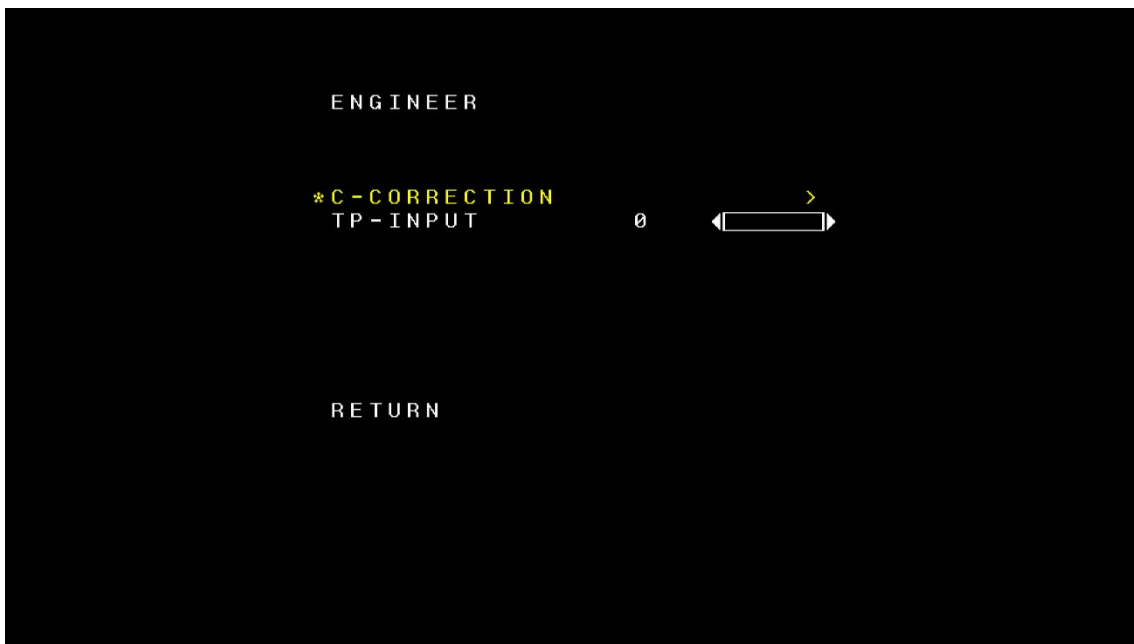

(1) C-CORRECTION

Configures settings related to color correction in the sub menu.

(2) TP-INPUT

Selects the test pattern to be displayed.

- 0 : OFF
- 1 to 9 : Display of test pattern
- 10 : Cross-hair at the center

7-9-1 COLOR CORRECTION TUNING

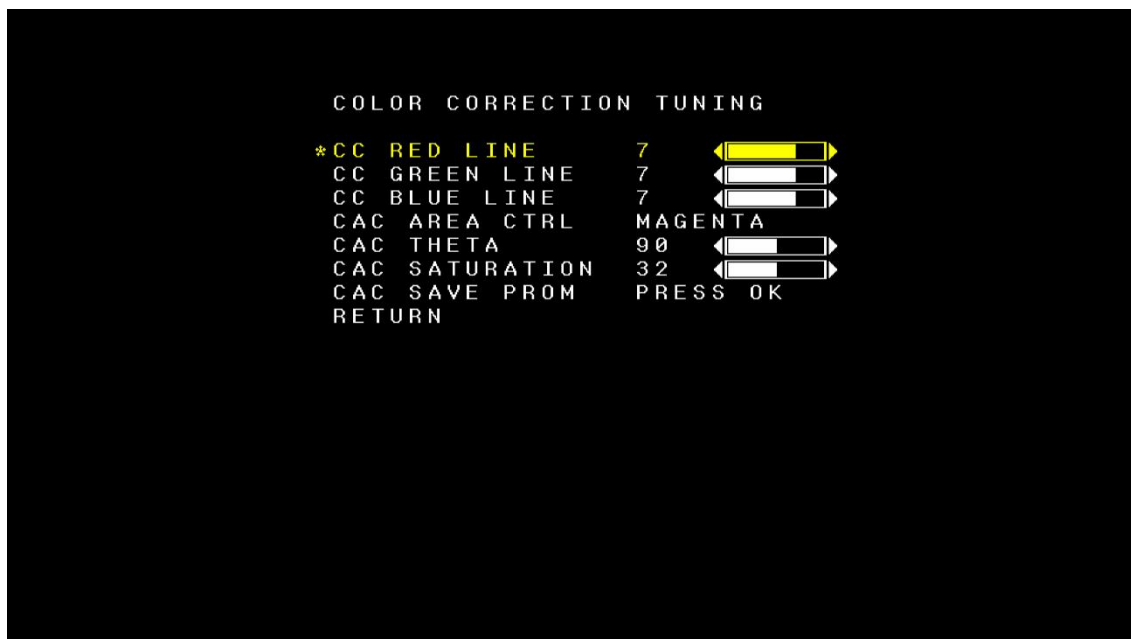

(1) CC RED LINE / CC GREEN LINE / CC BLUE LINE

Sets the value of the color correction coefficient.

(2) CAC AREA CTRL

Selects the adjustment area for CAC (Chroma Area Control).

MAGENTA / RED / YELLOW / GREEN / CYAN / BLUE

(3) CAC THETA

Adjusts the hue of the selected area.

As the discontinuity of the color space significantly increases, we recommend that you set a value between 80 and 100.

(4) CAC SATURATION

Adjusts the saturation of the selected area.

If you set a value close to 0 or 64, there is a possibility of small block noises being generated in strong color depending on the image scene. Setting this to "0" will not produce monochrome images.

(5) CAC SAVE PROM

Saves the CAC adjustment setting value.

8. Disclaimer

- We do not take any responsibility for fires, earthquakes, floods, lightning strikes, acts by third parties, other accidents, customer intentional or negligence, misuse, or failures, damages, and damages (including items caused by third parties) caused by use under abnormal conditions.
- We are not responsible for any incidental damages (loss of business profit, interruption of business, change or loss of memory content, etc.) arising from the use of this product or inability to use this product.
- We are not responsible for any damage caused by not complying with the contents described in this manual.
- We are not responsible for any damage caused by malfunction, etc. due to combination with connected devices.
- The warranty period for this product is one year from the date of delivery.
- Do not disassemble or modify this product. Even within one year after delivery, the warranty will no longer be valid.
- We are not responsible for any failure or damage caused by maintenance, repair, etc. by the vendor from which you purchased this product or by anyone other than our company.
- Items not described in the specifications of this product are not covered by the warranty, and our company does not take any responsibility.

9. Federal Communications Commission

This device complies with part 15 of the FCC Rules. Operation is subject to the following two conditions: (1) This device may not cause harmful interference, and (2) this device must accept any interference received, including interference that may cause undesired operation.

Note: This equipment has been tested and found to comply with the limits for a Class A digital device, pursuant to part 15 of the FCC Rules. These limits are designed to provide reasonable protection against harmful interference when the equipment is operated in a commercial environment. This equipment generates, uses, and can radiate radio frequency energy and, if not installed and used in accordance with the instruction manual, may cause harmful interference to radio communications.

Operation of this equipment in a residential area is likely to cause harmful interference in which case the user will be required to correct the interference at his own expense.

10. Environmental protection notice

At the end of its life span, this product may not be disposed as normal household waste. It must be disposed of at a collection center for recycling of electrical and electronic equipment or contact the manufacturer directly. The product label, inside the manual, or on the packing points to this information. The materials are recyclable according to their labelling. Through reusing, material recycling, or other forms of utilization of old devices you are making an important contribution to the protection of the environment. Please ask your local administrator for the responsible waste disposal center or contact the manufacturer.

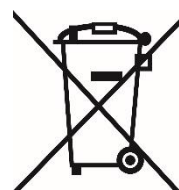

11. Others

The product specifications are subject to change without prior notice for product improvement. The functions, designs, etc. provided in this instruction manual are subject to change without prior notice. We kindly ask for your understanding.