



Harsh environmental resistance **GigE Vision** Series

12 MP Color Camera

KC1200GC3CX

 Anti-vibration

 Anti-shock

 Oilproof

 Dustproof

 Waterproof



Waterproof, dustproof, oilproof, shock and vibration-resistant imaging Camera

This product is an industrial camera equipped with a **global shutter**,
CMOS image sensor and **GigE interface**.

Applicable Standards

Vibration test 10G : pass

Shock test 75G : pass

Anti-vibration: IEC60068-2-6(JIS C60068-2-6)

Anti-shock: MIL-STD-810H

Features

- C mount Camera
- High performance and high quality
- Extensive know-how and solid technical capabilities

Applications

- Inspection
- Measurement
- Robot vision
- Food, Pharmaceuticals

Recommend Lenses Series



FC24M

EC-IR

XC



Kowa Optimed Deutschland GmbH

Specifications

Feature	Description
Monochrome / Color	Color
Interface	GigE Vision
Sensor	IMX545
Sensor size	1/1.1"
Resolution	4128(H) x 3008(V)
Pixel size (μm)	2.74(H) x 2.74(V)
Electronic shutter	Global Shutter
Frames per second	8fps
Power supply	PoE or DC24V
Power consumption	Less than 6W
Operating temperature	0°C - +45°C (No condensation) ※Appropriate heat radiation is required
Operating humidity	20% - 80%RH (No condensation)
Storage temperature	-30°C - +60°C (No condensation)
Storage humidity	20% - 90%RH (No condensation)
Operational vibration	10G
Operational shock	75G
Dimensions (mm)	45(W) x 45(H) x 38(D) (Excluding Projections)
Lens mount	C mount
Weight (without lens)	Approx. 140g
Environment	IP67, Oil proof

Dimensions

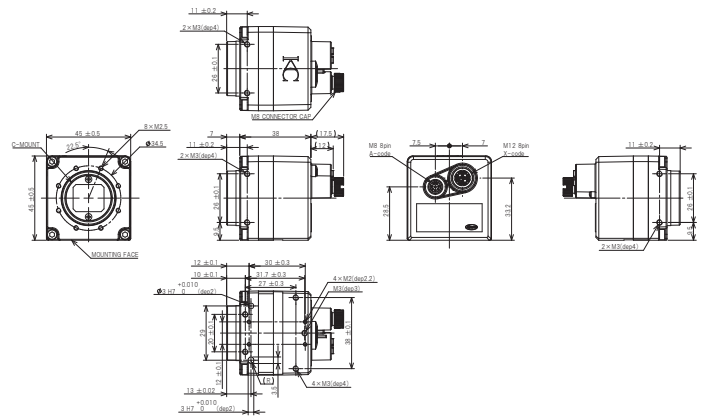

Spectral response and quantum efficiency

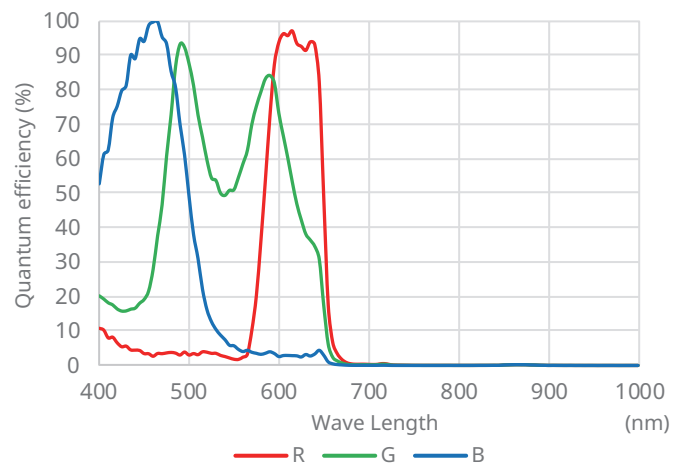

Connector pin assignment

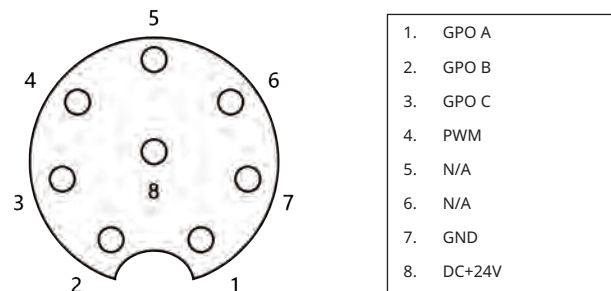

Kowa Optimed Deutschland GmbH

Please feel free to contact our team with any questions or further enquiries at
vision@kowaoptimed.com
 we will be happy to provide assistance and consultation.

Fichtenstr. 123, 40233 Duesseldorf, Germany
 TEL: +49-(0)211-542184-0
www.kowa-lenses.com

Kowa Optronics Co.,Ltd.

2F Kudan Center Bldg. 4-1-7, Kudan-Kita,
 Chiyoda-Ku, Tokyo, Japan
 TEL : 03-5651-7050

6-29, Nishiki 3-chome, Naka-ku,
 Nagoya, Aichi, Japan
 TEL : 052-963-393